

ANKO-MH-500 Telecom Cover 600x800 mm

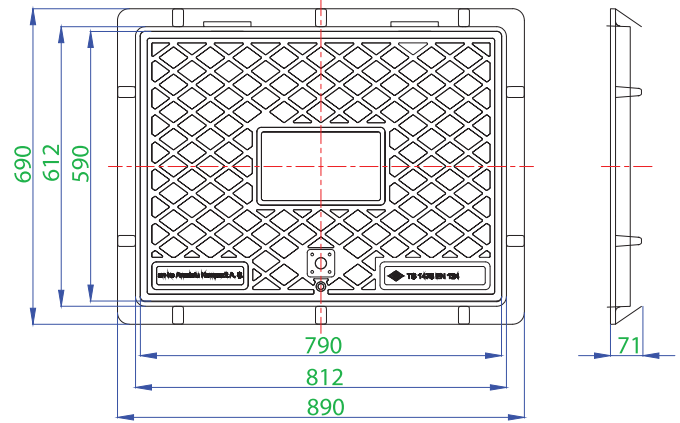

Product Code	Type	Class	Load (ton)	Weight (kg)
ANKO-MH-500C	Medium Duty	C250	25	34
ANKO-MH-500B	Medium Light Duty	B125	12.5	34

ANKO-NG-S700 (S700 NATURAL GAS BOX) Regulator suitable for use with a capacity of 6 m³ to 50 m³

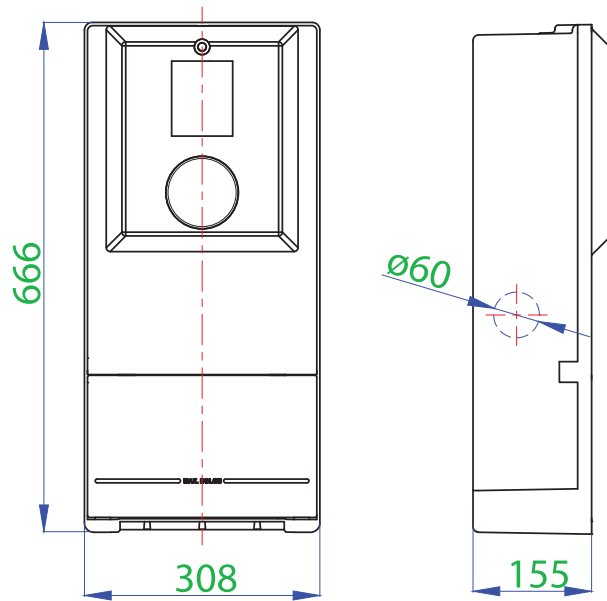

Product Code	Type	Weight (kg)
ANKO-NG-S700	Outdoor	5.5

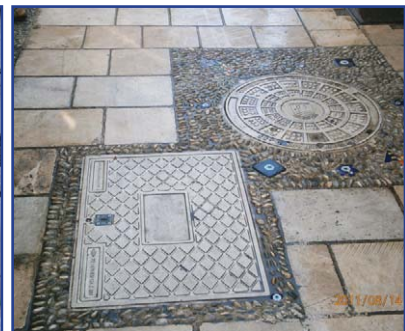

Features

- * For use aboveground.
- * There is a locking mechanism
- * Long-lasting.
- * Stainless, maintenance-free.

- * Light product provides ease of transport and assembly.
- * Non-flammable, self-extinguishing
- * Wide color range
- * Logo application available upon request